



*Accident
on 25 July 2000
at "La Patte d'Oie"
in Gonesse (95),
to the Concorde,
registered F-BTSC,
operated by Air France*

INTERIM REPORT (15/12/2000)

Translation

f-sc000725ae

F O R E W O R D

This document reports on the progress of the technical investigation as of 15 December 2000, and adds to the preliminary report published by the BEA on 31 August 2000. Only updated or new paragraphs are included and their numbering is the same as that of the preliminary report.

The investigation is still continuing, not all of the examinations of parts have been completed and certain points may evolve further. Although the objectives of some examinations and studies are indicated, only when all of the work undertaken is completed will it be possible to draw conclusions on the circumstances and causes of the accident.

In accordance with Annex 13 of the Convention on International Civil Aviation, with EC directive 94/56 and with Law N°99-243 of 29 March 1999, the analysis of the accident and the conclusions and safety recommendations contained in this report are intended neither to apportion blame, nor to assess individual or collective responsibility. The sole objective is to draw lessons from this occurrence which may help to prevent future accidents or incidents.

In accordance with Law n° 78-753 of 17 July 1978, this document is released subject to literary and artistic copyright. Copying, distribution or the use of this document for commercial purposes is forbidden.

SPECIAL FOREWORD TO ENGLISH EDITION

This report has been translated and published by the Bureau Enquêtes-Accidents to make its reading easier for English-speaking people. As accurate as the translation may be, the original text in French is the work of reference.

Table of Contents

F O R E W O R D	2
SYNOPSIS	4
UPDATE ON THE INVESTIGATION	5
PRELIMINARY REPORT ERRATUM	7
COMPLETED PARAGRAPHS	8
<i>(the paragraph numbers correspond to those in the preliminary report)</i>	8
10.2 Runway Inspections	8
10.2.1 Regulations	8
10.2.2 The inspections on 25 July 2000	8
11.3.2 Engines	9
16.4 Previous Events	10
16.4.1 Nature of Events	10
16.4.2 Events which caused Structural Damage to Tanks	11
16.4.2.1 Accident on 14 June 1979 at Washington	13
16.4.2.2 Other Events	14
16.4.3 Statistical Factors	15
NEW PARAGRAPHS	17
<i>(These paragraphs are additions to the preliminary report)</i>	17
12.3.5 Examination of the landing gear	17
16.6 Metal strip found on the runway	18
16.6.1 Findings on the aircraft	19
16.6.2 Manufacturer's documentation	21
16.6.3 Maintenance	21
16.7 Tank 5 rupture mechanism	22
16.8 Possible origin of combustion	23
16.9 Observations on the engines	26
16.9.1 Engine n°1 S/N CBE 031	26
16.9.2 Engine n°2 S/N CBX 115	27
18.1 Certification of Landing Gear and Tyres	27
18.1.1 General	27
18.1.1.1 Tyre Requirements	28
18.1.1.2 Landing gear Requirements	28
18.1.2 Means of Compliance at the Time of Certification	28
FIRST ANALYTICAL ELEMENTS : HISTORY OF THE FLIGHT	29
APPENDIX PREVIOUS EVENTS	35

SYNOPSIS

Date and time

Tuesday 25 July 2000 at 14 h 44¹

Aircraft

Concorde
registered F-BTSC

Site of accident

La Patte d'Oie in Gonesse (95)

Owner

Air France

Type of flight

Charter flight
Flight AFR 4590

Operator

Air France

Persons on board

Flight Crew: 3
Cabin Crew: 6
Passengers: 100

Summary :

During takeoff from runway 26 right at Roissy Charles de Gaulle Airport, shortly before rotation, the front right tyre of the left landing gear ran over a strip of metal which had fallen off of another aircraft, was damaged and pieces of the tyre were thrown against the aircraft structure. A major fire broke out under the left wing. Problems appeared shortly afterwards on engine N° 2 and for a brief period on engine N° 1. The aircraft was neither able to climb nor accelerate. The crew found that the landing gear would not retract. The aircraft maintained a speed of 200 kt and a radio altitude of 200 feet for about one minute. Engine N° 1 then lost power, the angle of attack and bank increased sharply then thrust on engines N° 3 and 4 fell suddenly. The aircraft crashed onto a hotel at La Patte d'Oie in Gonesse.

	People			Equipment
	Killed	Injured	Uninjured	
Crew	9	-	-	Destroyed
Passengers	100	-	-	
Third parties	4	6	-	

¹ Except where otherwise noted, the times shown in this report are expressed in Universal Time Co-ordinated (UTC). Two hours should be added to obtain the legal time applicable in metropolitan France on the day of the accident.

UPDATE ON THE INVESTIGATION

After the publication of the preliminary report, the investigation continued, in close co-operation with the representatives of the investigative organisations and companies concerned, and in co-ordination with those responsible for the judicial investigation.

The Commission of Inquiry held three further meetings during which it was informed of the progress of the investigation, discussed and approved the draft interim report. Several of its members participated in the BEA's work.

Four working groups replaced those in the initial organisation.

- Wreckage.
- Conduct of flight and aircraft performance.
- Previous events, certification and regulations.
- Technical research.

Work on the wreckage is continuing, particularly on that on the left side of the aircraft (dry bay, wing, landing gear well), the debris from which has been gathered together for examination and positioning, with attendant delays due, amongst other things, to the presence of asbestos.

Research has been undertaken into the causes of the fuel leak and into the ignition and development of the fire.

Examination of the engines, tyre debris, pieces of tank N°5 and of the landing gear are being undertaken in the context of the judicial investigation and are subject to the constraints of this procedure. The BEA participates in these examinations. Examination of the Flight Engineer's panel has been requested.

American and French investigators were able to examine the aircraft which had lost the strip of metal which caused the cut in the tyre.

At this stage of the investigation, the following scenario appears more and more probable.

The Concorde taking off from runway 26R at a speed of 175 kt ran over a strip of metal from a DC 10 which had taken off a few minutes before. This strip cut the tyre on wheel N° 2 of the left main landing gear, as part of a process that remains to be determined. One or more pieces of the tyre were thrown against the underside of the wing at the level of tank N° 5. This led to the rupture of the tank as part of a process, currently under study, which appears to associate the deformation of the tank wall and the propagation of the shock wave through the kerosene. A significant leak resulted from this. The escaping kerosene was whisked around in the turbulence around the landing gear and caught fire. The causes of the combustion are still being researched. Engines 1 and 2 then encountered severe problems, either through ingesting pieces of tyre or other pieces of the plane, or more likely through the kerosene leak itself and/or through the hot gases caused by the com-

bustion of the kerosene. The aircraft took off with a very large stabilised flame that caused structural damage throughout the flight. The engine 2 fire alarm came on, and the crew announced shut down of this engine a few seconds later. The aircraft was flying at low speed and remained at a low altitude. The crew noticed that the landing gear would not retract, this non-retraction being explicable either by damage to circuits or systems following shocks resulting from the destruction of the tyre, or by exposure to flames. The crew mentioned a possible landing at Le Bourget aerodrome. The loss of power on engine 1 that occurred a few seconds later probably resulted from the ingestion of a mixture of hot gases/kerosene and internal damage caused by the previous ingestion. Aircraft angle of attack and bank then increased sharply, control of the aircraft was lost as a result of a combination of thrust asymmetry, due to profound thrust-drag imbalance and, perhaps to structural damage caused by fire. The thrust of engines 3 and 4 fell suddenly due to slipstream distortion. The aircraft crashed.

PRELIMINARY REPORT ERRATUM

Position	Correction
page 6 Glossary	ASDA : read "Accelerated Stop Distance Available"
Page 7 Glossary	TCAS : read " Traffic Alert and Collision Avoidance System" TODA : read "Take Off Runway Distance Available" TORA : read "Take Off Runway Available"
page 12 5.1.2	Flying hours as instructor, read : "not calculated before after 1997"
page 19	Erase first line
page 21 6.6	Read ...Taxi weight 186 880 kg Takeoff weight 185 070 kg
page 27 9.2.4	Readrunway 26 right wind 090 8 kt...
page 38 12.1.1	Photo caption, read : "Part found at slab 466 157 level : right part of deflector"
page A17 appendix 4	Read : "Control Column Position (deg) (+ Nose Up) (+ Nose Down)"
page A3 – appendix 2	Read : Beginning of recording : 14 h 12 min 23 s

COMPLETED PARAGRAPHS

(the paragraph numbers correspond to those in the preliminary report)

10.2 Runway Inspections

10.2.1 Regulations

Surveillance of the condition of the movement area² of French aerodromes is derived from the standards and practices recommended in Annex 14 to the Chicago Convention.

For an aerodrome of the size of Paris Charles de Gaulle, ICAO recommends carrying out inspections at least twice a day in order to monitor the condition of the movement area and to communicate information relating to operations or concerning aircraft performance.

The ICAO Airport Services Manual, in part 8 of the 1983 edition - Operations, and the ICAO manual on guidance and control of ground traffic also contain indications on daily inspections of the movement area.

Aéroports de Paris note 10/AD/98 specifies three daily inspections in addition to the lighting inspection : before 07 h00, around 14 h 00 and around 21 h 00 local time.

10.2.2 The inspections on 25 July 2000

On July 25 at around 04 h 30³, a « Follow Me » vehicle performed a runway inspection in two passes. Nothing unusual was reported.

At around 14 h 30, a « Follow Me » vehicle performed a partial runway inspection in the area of taxiway W2 following a suspicion of a bird strike.

Between 14 h 35 and 15 h 10, an exercise with several fire brigade vehicles took place on runways 26 right and 26 left. Taking into account this exercise, the runway inspection planned for 15 h 00 was put back. It had not been carried out at the time the Concorde took off (16 h 42 min 30s).

*
* *

² Movement Area : That part of an aerodrome to be used for the takeoff, landing and taxiing of aircraft, consisting of the manoeuvring area and the apron(s).

³ In this paragraph, times are given in local French time.

11.3.2 Engines

This paragraph presents the readout of the engine parameters, correlated to the observations made during teardown of the engines (see para. 16.9). Note that these parameters are recorded every four seconds. The following items result from an in-depth analysis of the available data, calculated times being rounded to the nearest second.

Note : Engine rotation speeds (N1 for the low-pressure compressor and N2 for the high-pressure compressor) show an identical shift in relation to the theoretical value for all four engines. This can be considered to be an error in the recorded values. The following comments allow that this is the case.

The takeoff power of the engines and their behaviour during the initial phase of takeoff, until time 97602, is normal on all four engines with a longitudinal acceleration (Nx) of 0.268 g.

From time 97603, (that's to say from 14 h 43 min 12 s) significant changes appear on engines 1, then 2. The evolution of the N1 and N2, EGT, fuel flow and P7⁴ parameters indicate a slight deceleration on engine 1 and a strong deceleration on engine 2. At time 97603 the Nx is recorded at its minimum value of 0.133 g. At time 97604 the aircraft heading veered to the left (2°/s) and, in reaction, the rudder pedal deflection increased to the right. It was during this period of time that the Control Tower signalled flames at the rear of the aircraft and that the green lights (GO LIGHTS) for engines 1 and 2 went off.

At time 97606, engine 1 recovered around 90 % of its thrust. At time 97608 it can be noted that its GO LIGHT came on again.

At time 97607, engine 2's P7 parameter fell to 17.30 Psi (for a nominal value of around 42) and the fuel flow indicated 0.95 t/h (for a nominal value of around 23 t/h). This fuel flow is lower than the idle flow and close to the minimum the governor can order following an excess EGT limit or a sudden drop in N2.

At time 97610, engine 1 parameters were close to normal. The GO LIGHTS were off on engines 1, 3 and 4 (this is the normal result of shock absorber decompression).

At around time 97613, the fire alarm for engine 2 sounded.

At time 97614, engine 1 parameters show a significant deceleration. N2 fell to 74.8 % and the fuel flow was close to the idle flow rate.

At time 97615, engine 2 parameters are recorded as falling slightly though they were increasing a few seconds before. On the CVR recording, the FE announces « shut down engine 2 ». A noise similar to that of the fire handle being pulled is heard four seconds later.

⁴ This parameter indicates the engine thrust..

At time 97618, engine 2's N2 speed falls below 58 %. In the same second, engine 1's parameters improve, N2 reaching 89.7%. From time 97620, the parameters for engines 3 then 4 show behaviour consistent with a modification from TAKE OFF to CONTINGENCY. The fuel flow, adjustable jet and P7 pressure are consistent with reheat being in operation on these engines.

At time 97619, the recorded fuel flow for engine 2 has a zero value ⁵. N1 and N2 are normal for a windmilling engine in these flight conditions.

At time 97626, engine 1 also reached an N2 CONTINGENCY speed, though the P7 indicates thrust in the region of that delivered by an engine on full power with reheat but without CONTINGENCY.

Around times 97632 and 97633, a second alarm from engine 2 and its associated gong are heard.

Around time 97649, the engine 2 fire alarm and the associated gong went off for the third time even though this alarm had stopped four seconds before. The alarm continued until the end of the recording.

At times 97650 and 97658, fuel flow and P7 on engine 1 show signs of fluctuation. At time 97662, that engine's parameters drop sharply. From time 97676, the parameters on engines 3 and 4 also show a significant deceleration.

*
* *

16.4 Previous Events

16.4.1 Nature of Events

Research was undertaken to find incidents which had involved tyres or landing gear on the Concorde since its entry into service. The information collected to establish the list of events came from the archives of EADS, Air France, British Airways, BEA, AAIB, DGAC, CAA and Dunlop.

The list in the appendix shows information from events coming from at least two different sources or for which reports or detailed information exist.

⁵ This parameter is recorded with a zero value when the flow rate is below 500 kg/h.

In the list, there are fifty-seven cases of tyre bursts/deflations, thirty for the Air France fleet and twenty-seven for British Airways :

- Twelve of these events had structural consequences on the wings and/or the tanks, of which six led to penetration of the tanks.
- Nineteen of the tyre bursts/deflations were caused by foreign objects.
- Twenty-two events occurred during takeoff.
- Only one case of tank penetration by a piece of tyre was noted.
- None of the events identified showed any rupture of a tank or a fire, whether leading or not to a significant simultaneous loss of power on two engines.

History of events involving tyres on Concorde (AFR ; BA ; confirmed)

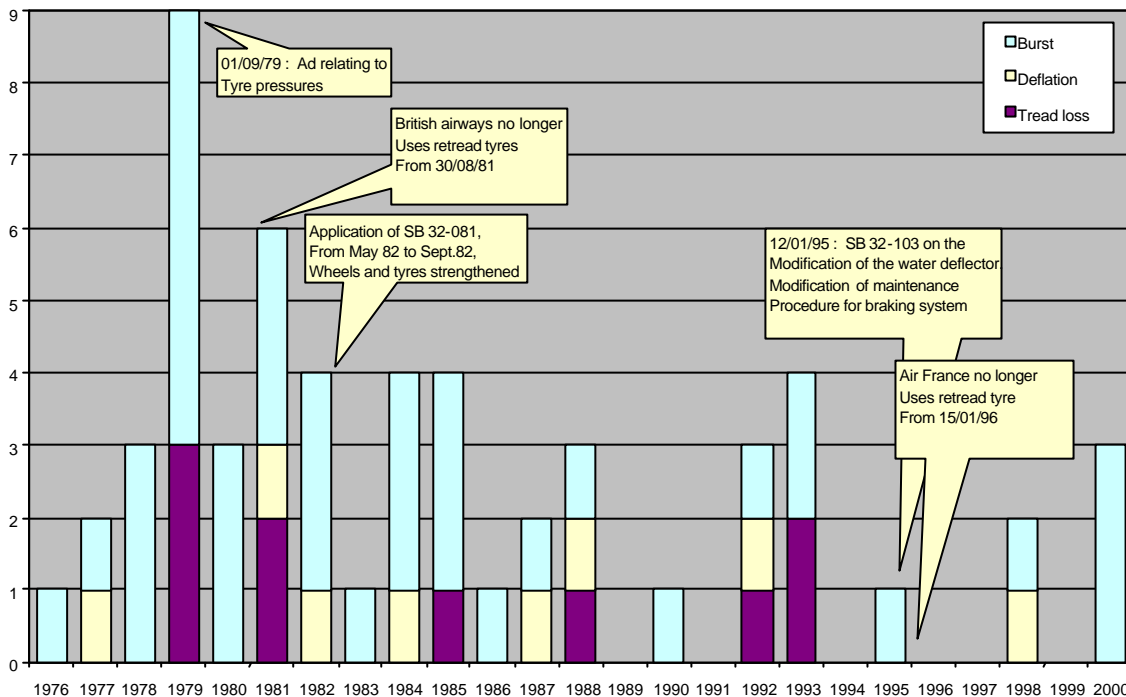

Twenty-one other events were notified by a single source, but no reports or detailed information exist for them. No mention was made of damage to the structure or the wings in any of them.

16.4.2 Events which caused Structural Damage to Tanks

14 June 1979: F-BVFC on takeoff from Washington Dulles Airport. Deflation of tyre n° 6 followed by loss of tread, leading to burst of tyre n° 5 and the destruction of wheel n°5 and small perforations in tanks 2, 5 and 6. After some unsuccessful attempts to retract the landing gear, the loss of the Green hydraulic system and a drop on the Yellow system to the first low level, the crew landed the aircraft back at Washington twenty-four minutes later.

9 August 1981: G-BOAG on takeoff from New York JFK, burst of n° 1 and n° 2 tyres leading to minor penetration of tank n° 5.

15 November 1985: G-BOAB on takeoff from London Heathrow, burst of n° 5 tyre causing damage to the landing gear door. Minor penetration in tank n° 5, probably by a piece of the door mechanism.

29 January 1988: G-BOAF on takeoff from London Heathrow, loss of six nuts from n° 3 wheel. A bolt punctured tank n° 7.

15 July 1993: G-BOAF on landing at London Heathrow, burst of n° 4 tyre leading to damage to the gear door mechanism. Tank n° 8 was damaged, probably by a piece of this mechanism.

25 October 1993: G-BOAB during taxiing at London Heathrow, burst of n° 2 tyre leading to damage to the water deflector. Tank n° 1 suffered minor penetration, probably from a piece of the deflector.

Location of impacts with penetration during the various incidents (right wing and left wing)

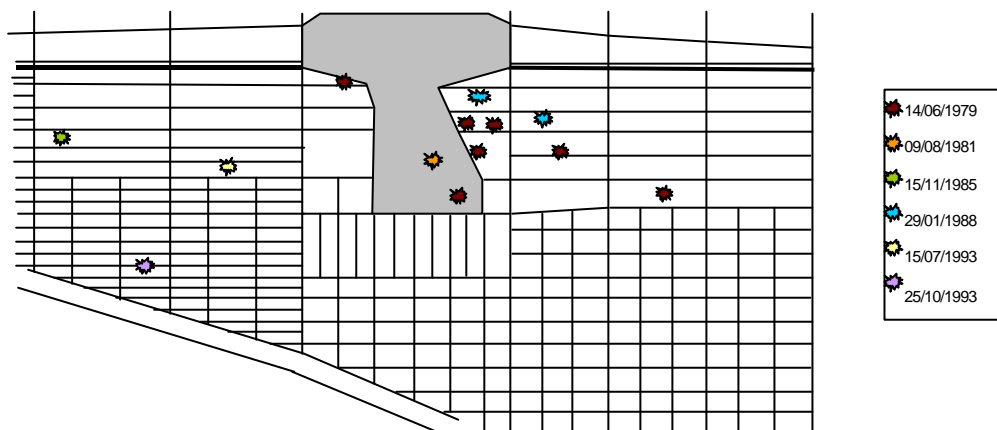

Note that :

- Four of these events occurred during takeoff. Amongst these, in one case the tyre damage was caused by an object on the runway, in two cases the tyre burst occurred for reasons which were not determined, the final case being due to tyre deflation while the aircraft was rolling at high speed. One of these events resulted in an aborted takeoff. In the three others, the aircraft took off and then returned to land.
- One event occurred on landing. The tyre burst was caused by a braking system jam.
- The last event occurred during taxiing when the aircraft was leaving the runway. The tyre burst was also due to a braking system jam.

16.4.2.1 Accident on 14 June 1979 at Washington

Among the events which led to tank penetration, that of 14 June 1979, which occurred to F-BVFC at Washington, was both the first of its type and that which caused the greatest damage.

Most of the structural damage resulted from impacts from pieces of wheel rim on the wing, aft of the tyres. Three penetrations were also observed in the area of tanks 2, 5 and 6, whose wall thickness is 1.2 mm. One of them was caused by a piece of rubber from a tyre. The resulting fuel leak from all of the penetrations was 4 kg/s.

Following this accident, a report was made by the BEA and a study was carried out by Aérospatiale to find solutions aimed at limiting any risks linked to tyre bursts on the Concorde.

This study concluded that the risk factor was higher in probability and consequence than that which had been taken into account at the time of certification. The observed and potential consequences were mentioned and the major risks identified. In case of a tyre burst during takeoff, these included :

- Risk to the nacelle. The study indicated that, during certification, it was shown that damage suffered by the nacelles in case of impact by four pounds of tyre debris at a speed of 217 kt was not liable to compromise engine function.
- Risk to engine. The study recalled the conclusions of the work on debris ingested by the engines. In case of ingestion of large debris, loss of thrust was rapid and total, only the inner engines were liable to be affected, and this only in the case of an outer tyre burst. This analysis was based on considerations of size and of the position of the air intakes in conjunction with the study of the trajectories of the debris. In the case of smaller debris, and based on experience gained in service from aircraft with similar geometry (Vulcan, Comet, Nimrod), a significant loss of thrust was considered to be extremely unlikely.
- Risk of penetration of feeder tanks. Taking into account the separation of the feeder tanks supplying two adjacent engines, the study considered that the risk of simultaneous penetration of the two feeder tanks was sufficiently low. Continued fuel supply to the engines in case of a leak was also considered and the study concluded that these two engines could continue to run for at least twenty minutes.
- Risk of fire. Based on the data about the leak in the accident, the study concluded that the risk of fire was limited, considering :
 - That the size of the penetrations and the rate of flow of the leak are sufficiently low;
 - That combustion cannot be caused by rubber or metal debris penetrating the tank;
 - That the fuel leaks from tanks 6 and 7 follow the flow under the wing and remain generally parallel to the aircraft axis without meeting areas of sepa-

ration and thus dissipate via the wing trailing edge .The secondary nozzle's temperature is too low to ignite the fuel.

- That fuel from leaks in tanks 5 and 8 may accumulate in the landing gear well. Only the electrical circuits in this compartment constitute a possible source of ignition;
- That ignition of the fuel on contact with hot brakes would not be systematic, bearing in mind the average temperature reached by the brakes ;
- That in case of penetration of the tanks forward of the air intakes, leaks would be limited (due to the limited size of the debris taken into consideration) and could only enter the engine at a very low speed (after landing) and at a high thrust level.

Most of the solutions then proposed were in fact put into effect and were the subject of Airworthiness Directives :

- AD of 14/01/8, applied from 21/01/81, calling for the installation of a system for detection of main landing gear tyre under-inflation. An improved version of this system was then applied by AD on May 15 1982.
- AD of 14/01/81, applied on 21/01/81, calling for improvements in protection in the normal braking hydraulic system,
- AD of 5/05/82, applied on 15/05/82, defining an inspection procedure for the main landing gear tyres and wheels before each takeoff,
- AD of 5/05/82, applied on 15/05/82, calling for the installation of new reinforced wheels in order to limit damage in case of contact with the ground and for new reinforced tyres capable of bearing twice the normal load (the regulations require one and a half times).

As a result of studies carried out on the risks of damage from pieces of tyre and on trials performed at the CEAT in 1980 to justify the integrity of the structure in case of direct penetration, it was concluded that it was not necessary to install protection for the underside of the wings.

16.4.2.2 Other Events

All of the tank penetrations that occurred after the Washington accident involved aircraft operated by British Airways. It should be noted that after the modifications carried out after the Washington incident, tank penetrations following a tyre burst were caused only by metallic debris. In most cases, this debris came from the destruction of equipment located in the landing gear area, probably dislodged by the rotation of the damaged tyre. The pieces in question include the water deflector and the gear door latch.

The deflectors were the subject of an optional Service Bulletin (see § 6.2.4).

A solution of the same type to limit the consequences of the rupture of the gear door latch is being studied by British Airways and EADS.

In addition, the recommendations of a working group responsible for studying braking problems after the 1993 incidents were implemented in the form of modifications to maintenance procedures.

16.4.3 Statistical Factors

At the time of certification, it was considered that the possibility of a double tyre burst on a Concorde could be assessed as extremely rare (probability lower than one occurrence per 10^7 flying hours). In the light of in-service experience, the study carried out by Aérospatiale after the 14 June 1979 accident defined this occurrence as rare (probability between 10^{-5} and 10^{-7} per flying hour).

As of 25 July 2000, it appears that the rate of tyre bursts/deflations on Concorde was of the order of one occurrence per 1,500 cycles (or 4,000 flying hours). In comparison, on a long-haul aircraft such as the Airbus A340, this rate is of the order of one occurrence per 100,000 cycles⁶.

If only events occurring on takeoff are considered, since they are representative of the accident, it is noticeable that tyre damage was caused by a foreign object in 50% of the cases.

It is also possible to calculate the rate of events on takeoff relative to the number of cycles. Three periods can be distinguished: before 1982, when no modifications of the tyres or landing gear had been carried out. Between 1982 and 1994, when all aircraft had been modified as detailed in § 16.4.2.1. After 1994, when the braking system maintenance procedure had been modified and British Airways planes had, in addition, been equipped with modified water deflectors.

	Cycles	Events on takeoff	Rate
1976-1981	24 052	13	$5.4 \cdot 10^{-4}$
1982-1994	42 628	8	$1.9 \cdot 10^{-4}$
1995-2000	17 261	1	$0.6 \cdot 10^{-4}$
Total	83 941	22	$2.6 \cdot 10^{-4}$

⁶ This rate is calculated from airline incident reports. The collection of this information cannot be considered to be exhaustive since the percentage of non-reported incidents is unknown. This figure should thus be considered to be optimistic.

Reduced to the number of cycles, the evolution in the number of events is represented hereafter :

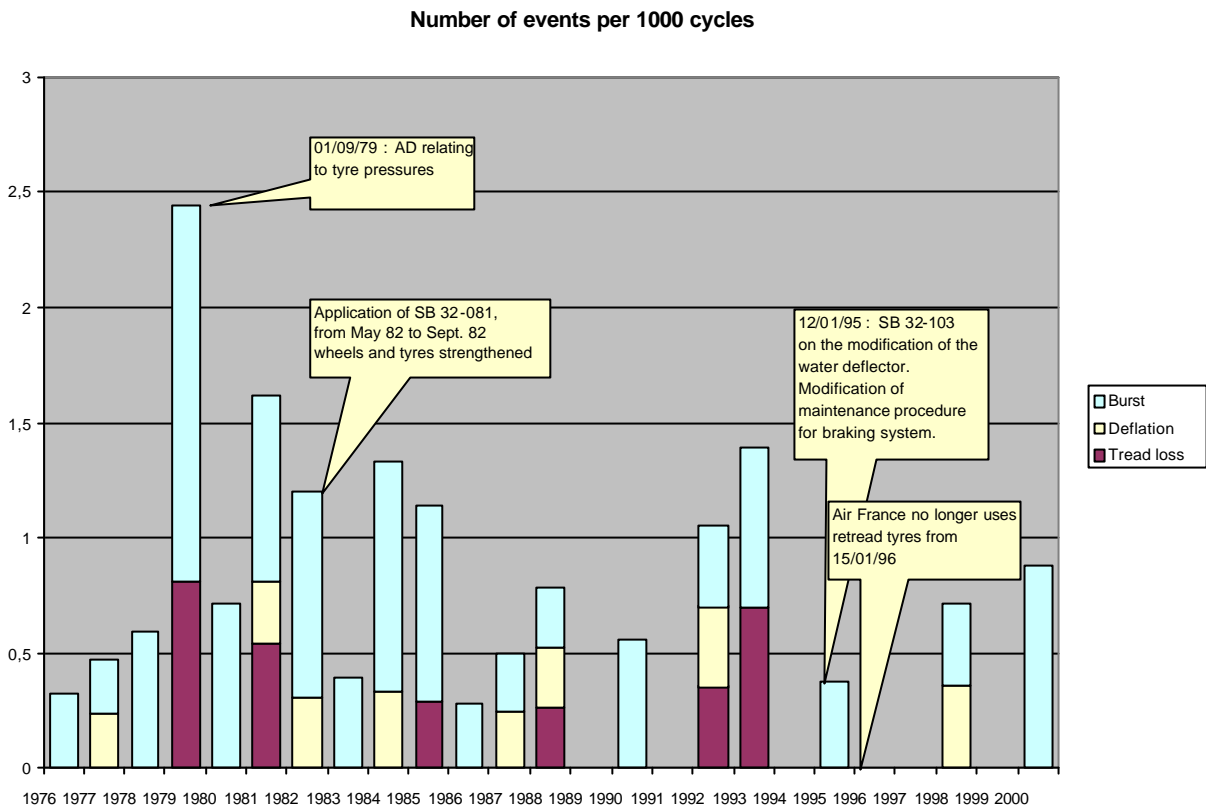

Note : bearing in mind the small number of events taken into account in this statistical approach, evolutions shown in this graph can only give an overall qualitative idea.

Note that, despite twenty-five years of commercial operation, the total number of cycles or of flying hours flown by Concorde is much lower than that for other civil transport aircraft. Some figures are given in the following table :

Aircraft Type	Flying Hours	Cycles
A 300	5 645 000	3 468 000
A 300-600	4 673 000	2 398 000
A310	7 258 000	2 755 000
A330	1 193 000	417 000
A340	2 757 000	439 000
Concorde	235 000	84 000

NEW PARAGRAPHS

(These paragraphs are additions to the preliminary report)

12.3.5 Examination of the Landing Gear

In the context of the reconstruction of the wing currently being undertaken, it has been possible to add to the observations made at the site of the accident, in particular concerning the landing gear and associated mechanisms.

This examination revealed the following points :

- The left main landing gear was extended and locked at the level of the side-stay. The right main landing gear was severely damaged but clearly identifiable in the extended position. The nose gear was released with its locking pin out.
- The two main landing gear door locks were in the open position.
- The left nose gear door closing actuator was released with movement of 100 mm. The normal course of this actuator is 35 mm when the door is closed and 195 mm when the door is open.
- The main landing gear door closing actuator was broken. An examination of this actuator should allow its movement at the moment of impact to be determined.
- A spacer, which holds two lateral rings in position, is missing from the oleo/bogie coupling on the left main landing gear. This retainer had not been re-installed after the AO1 check performed from the 17 to the 21 July 2000.

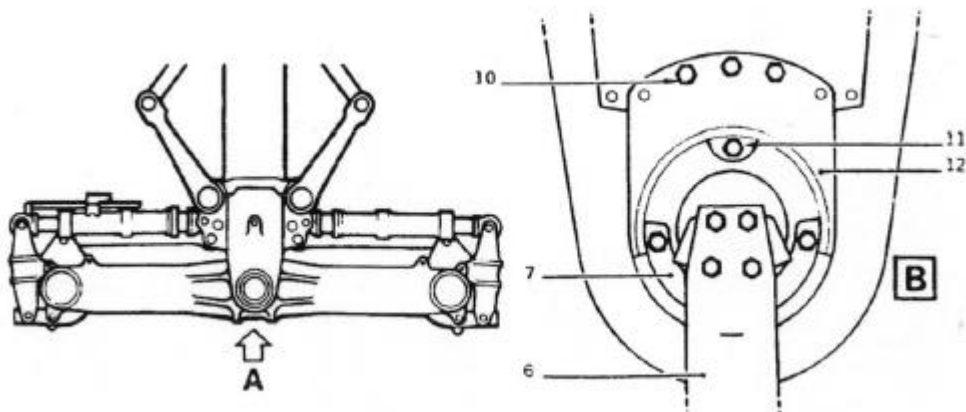

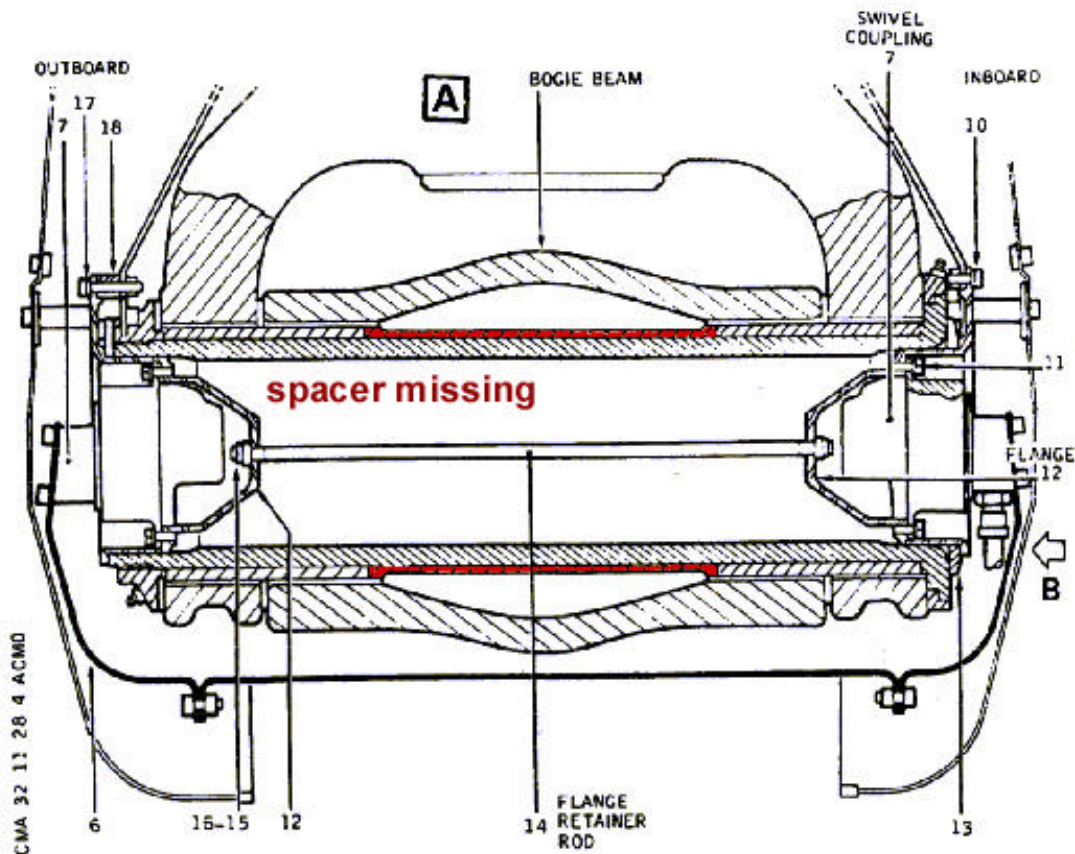

*
* *
*

16.6 Metal Strip Found on the Runway

The metal strip found on the runway after the accident (see Preliminary Report, § 12.1.3) appeared to be of a type used in aviation but not belonging to the Concorde. A search was therefore undertaken to identify the aircraft which it could have fallen from. This search was concentrated on the aircraft which had taken off from the same runway after 13 h 00. In addition, work on several types of aircraft led to a belief that the part could be a wear strip from a CF6-50 engine thrust reverser cowl.

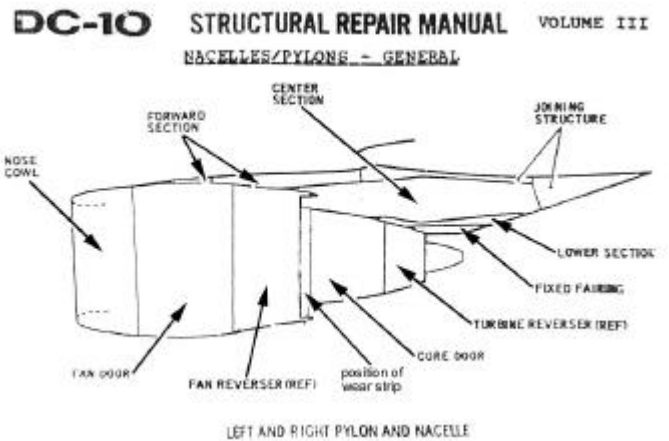
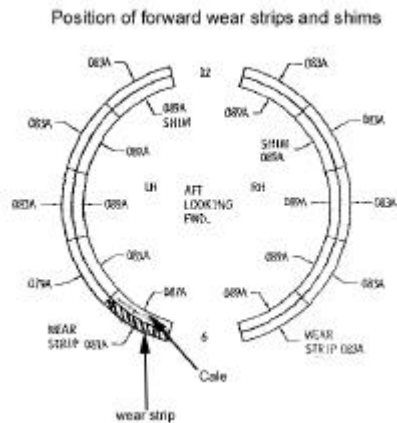

A DC10, registered N13067, had taken off five minutes before the Concorde to undertake flight COA 55 Paris-Newark. Since this aircraft, which had been observed briefly at Paris Charles de Gaulle on 30 August 2000, could have been the aircraft which lost the part, a technical investigator, assisted by the NTSB Accredited Representative and FAA specialists, went to its Houston base to examine it in the presence of the operator's representatives.

Note : only one aircraft, an Air France Boeing 747, took off between the DC 10 and the Concorde.

16.6.1 Findings on the Aircraft

The following findings were made on engine 3 on the aircraft :

a) Rear reverser cowl structure

- The lower left wear strip, about 44 cm long, was missing. The closed core cowl door normally rests on the front part of the wear strips ;
- The fitting had been painted with green epoxy primer ;
- In the missing part's position, the fitting had been coated with red type RTV106 mastic ;
- There were no traces of RTV 106 on the other parts of the fitting ;
- There were no traces of RTV 106 on the wear strips still in place ;
- There were numerous paint run marks on the fitting and on the wear strips. The paint partially spread over onto the fan cowl door ;
- In the position of the missing part, the fitting still had several rivets in place ;
- the fitting was drilled with thirty-seven holes, some of which had spaces less than twice their diameter between them.



b) Wear strips

- the right wear strips appeared to be original parts made of stainless steel (extruded profile at the tip)
- the left wear strips had been replaced, and do not appear to be original parts made by the manufacturer;
- the spacing of the rivets on the strips in position and their alignment appeared to be correct ;
- the level of wear on the strip adjacent to the missing strip was greatly in excess of the tolerance permitted by the manufacturer.

c) Lower right wear strip

- a rivet was missing on the strip. The strip was twisted and allowed play of 6 mm in relation to the fitting ;
- the rivet at the tip was broken off, the part remaining on the fitting prevented the strip from sticking to the fitting, which prevented correct closing of the cowl;
- in comparison with an original part, this strip was too long.



d) Left fan door

- from the outside, no anomaly was apparent ;
- inside, the presence of deep wear marks was noted, in particular on the part which normally rests on the strips ;
- to the right of the wear strip bearing point adjacent to the missing strip, deep wear marks were noted on the door, about 2 mm deep.

e) Fan door / reverser cowl closed

Once closed, the fan door / reverser cowl assembly did not reveal the absence of the lower strip.

16.6.2 Manufacturer's Documentation

The manufacturer's documentation specifies conditions for removal and repair of wear strips. Notice 78-32-03 (disassembly and repair) specifies on pages 901 to 905 the equipment and materials to be used and their operation. The notice specifies that no special tools are required.

The wear strip is made of stainless steel 0.055 inches (1.40 mm) thick and 1 inch wide. The notice indicates that the strip can be made from stainless steel in a workshop the dimensions then being 0.055 inches (1.40 mm) thick and 1.395 inches (35.43 mm) wide without extrusion.

It is specified that a template must be made in order to use the existing holes in the fitting and to drill the new wear strip to the correct dimensions. The holes for the rivets have a diameter between 3.063 and 3.73 mm

Delaminated shims are inserted between the wear strip and the fitting so that the diameter of the cowl fitting should be 72.18 inches \pm 0.09 inches. Wear tolerance of the strip is 0.030 inches (0.8 mm).

Note : it appears that checking this diameter is difficult to do according to the method recommended by the manufacturer. Consequently, either repairers do not insert the shims, which creates excess play between the forward and rear cowls, or the shims are inserted in a uniform manner under all the wear strips, the lower strip then being quickly removable with screws, so as to make it possible to remove the shim if it is impossible to close the rear cowl.

16.6.3 Maintenance

The maintenance documents for N13067 show that the left wear strips on engine 3 were replaced during a C check which was completed on 11 June 2000.

Work was performed on 9 July 2000 in Houston on the engine 3 reverser cowl. The mechanical report indicates that the lower left wear strip was changed during the work.

Various questions about maintenance were asked through the Accredited Representative but investigators have not yet received any answers.

Note : the strip found on the runway has been subjected to examination in a laboratory.

*
* *

16.7 Tank 5 Rupture Mechanism

The rupture mode originally mentioned to explain the hole in tank 5 was a direct penetration, from the exterior towards the interior of the tank. However, the first observations of the piece of tank found on the runway seem to indicate that the rupture occurred from the interior to the exterior. To explain the mechanisms of the rupture, a numeric simulation was developed by EADS based on the so-called « finite elements » method. This method involves decomposing the structure into small volumes on which an approximation of the laws of mechanics shows the behaviour of the solid and the fluid in question. Tank 5 was modelled with around 70,000 finite elements for the tank and around ten times that number to model the fuel it contained. The results of the tests carried out by the CEAT in 1980 on an empty tank were used to perform a first validation of this model. In almost all cases, the model and the test gave the same result ; where they differed, the deformations calculated during the simulation were always higher than those noted during tests.

According to the first results of the simulation performed with the conditions of the 25 July 2000 flight, the rupture of the tank could thus be explained by the conjunction of two phenomena induced by the shock, without penetration, from a large piece of tyre on the tank :

- a solid mechanics phenomenon inducing a wave of deformation on the wall of the tank,
- a fluid mechanics phenomenon, with propagation of a wave in the kerosene leading to a sort of action-reaction of the over-pressure effects on the lower wing skin.

Qualitative approach to the rupture scenario

☎ 1st rupture mode : direct penetration by dynamic shearing

☎ 2nd rupture mode : bending effect + excess hydraulic pressure

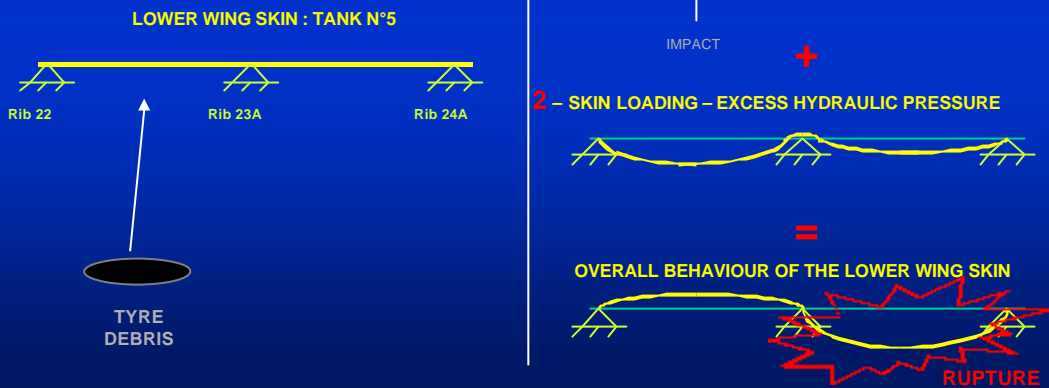

Diagram EADS/Airbus

However, validation of the model needs to be completed. To this end, tests will be undertaken at the CEAT on full or partially filled tanks. Consistency between the results of these tests and those of the numeric calculation will allow the model to be validated. Once validated, it will be possible to use it to obtain more precise information on the rupture, for example by varying certain parameters (tank fill, tyre impact zone, possibly even the number of impacts, since several pieces of tyre were found on the runway).

A « structure and damage » specialist from the ONERA is assisting the BEA in the validation of this approach.

*
* * *

16.8 Possible Origin of Combustion

On the basis of the known facts and based on the properties of turbulent flames, three points were studied :

- the mechanisms which may have led to the ignition then the propagation of the flame under the aircraft's wing.
- The stabilisation of a quasi-stationary turbulent flame under the wing during takeoff roll and flight phases.
- Estimation of the flow of fuel coming from the leak.

Ignition and propagation of the flame

Among the various potential sources of ignition which were identified in the course of the investigation, three were proceeded with and are the subject of further studies : electrical ignition (spark in the gear well), ignition following an engine surge, self-ignition in the hot gases near to or at the rear of the engines.

Electrical ignition is possible though difficult for a non-pre-mixed kerosene (in addition, the leak hole being about 25 cm from the edge of the gear well, the kerosene which might pass into it would still be very liquid, thus relatively difficult to ignite). This hypothesis appears to require the convergence of several favourable parameters (moment, length and energy of the spark, size of the kerosene droplets) and remains to be evaluated.

Ignition resulting from an engine surge is being studied with the assistance of the engine manufacturer.

Ingestion of kerosene into an engine would have led to a surge with flames projecting forward, which would have ignited the flowing fuel. Such a phenomenon could last a very short time (a few milliseconds) and remain invisible on the recorded data.

Finally, the hypothesis on self-ignition through hot gases is the subject of a study undertaken by two university researchers specialised in problems of turbulent combustion. The preliminary results of this study show that this hypothesis appears quite feasible. It does, however, pose the problem of the « backflow » of the flame under the lower wing surface, the length of the fuel stream flowing at around one hundred metres per second. This backflow appears to be possible, with a speed of about ten metres per second in relation to the aircraft, taking into account the chaotic phenomenon in turbulent combustion (that is to say the existence, locally, of recirculation zones with much lower speeds than those of the aircraft). It should be noted that the size of the leak (see below) appears to favour the possible mechanism of a backflow of the flame. Because of the chaotic nature of the turbulent combustion, numeric simulation would be inconclusive: the results would be too dependant on the model and the hypotheses selected. The study is ongoing and is taking into account additional items of information and research.

The hypothesis based on ignition of a possible hydraulic leak rather than of the fuel has also been examined but seems highly unlikely. Hydraulic systems are in fact found in the landing gear well which could have been damaged and caused a leak. However, no currently available information suggests any hydraulic loss; the auto-ignition temperature of M2V hydraulic fluid is much higher than that of kerosene; potential flow rates are much lower than those of the fuel leak.

Flame stabilisation and attachment

When an obstacle is placed in a flow, the development of turbulence is observed with recirculation zones. In these zones, the flow can move in the opposite direction to that of the main flow in some areas. This recirculation zone allows a flame front to stabilise through two mechanisms :

- The recirculation generates an area of low speeds,
- The recirculation zone contains burnt gases and acts as a reservoir for hot gases which contribute to the ignition, slightly downstream, of the fuel-air mixture.

These mechanisms may explain the stabilisation of the flame to the rear of the left landing gear, as can be seen on photos of the aircraft on takeoff. Indications of stabilisation of the flame are not therefore necessarily apparent on the gear struts, partly because the flame is slightly stabilised downstream and in part because the struts are continuously cooled by the flow from upstream.

Estimation of fuel flow

Based on photos and videos of the accident flight, the estimation of the fuel flow was carried out using two approaches, which give similar results. The first uses the *Magnussen* model, a simple model developed to describe the reaction rate of non-pre-mixed turbulent flames, that is to say where the reactive elements are injected into the reaction zone separately. Taking the hypothesis of a flame three metres in diameter, fifty metres long and ten centimetres thick, modelling leads to fuel consumption close to 60 kilograms per second.

In the second method applied, the *coherent flame* model equates the flame with a surface, and the reaction rate becomes the product of this surface and a surface reaction rate estimated according to a laminar flame model. According to this method, and in relation to the parameters selected for the size of the surface, the fuel consumption varies between twenty and one hundred and thirty kilograms per second, with a peak in probabilities (corresponding to average and realistic values of the size of the flame) of around sixty kilograms per second. This model thus confirms the overall rate established with the first model. .

In conclusion, the overall flow rate of the leak is several dozen kilograms per second, thus about ten times greater than in the Washington accident. This high rate of flow from the leak may have aided in the propagation of the flame, since it led to a fuel/combustive mixture close to or exceeding the stoichiometric values, a mixture which then becomes perfectly flammable.

*
* * *

16.9 Observations on the engines

Observations were undertaken by BEA investigators on engines 1 and 2 during teardown.

Note : The engines, as well as the internal elements which were dismantled, were washed in order to eliminate any possible presence of asbestos.

16.9.1 Engine n°1 S/N CBE 031

Module compressor

Ten blades from stage n° 1 in the compressor showed signs of hard body impacts with material dislodged. Impacts with loss of material were noted on the apex of the leading and trailing edges of the compressor rotor stages 1 and 2. They resulted from elasto-plastic deformation of the blades and from an untwisting of the blade apexes, with clashing with the stators of stages 1 and 2 of the LP compressor. Particular note should be made that blade n° 6 of the first stage compressor showed damage which could have come from impact with a metallic part with a flat perforated face .

Stage n° 4 of the compressor shows blade flexing in the opposite direction to rotation in the lower section and, to a lesser degree, in the upper section. This deformation corresponds to the crushing of the casing on impact with the ground.

It was noted that the upper half of the compressor discs had traces of overheating after impact, resulting from prolonged exposure to high temperature. The lower part of these discs was blackened by a soot deposit.

Taking into account the slight bend in the blades, the LP compressor was turning slightly on impact.

HP compressor module

The HP compressor module showed traces of ingestion of hard bodies. The blades of stages n°1 to 7 showed significant traces of impact.

The combustion chamber

The combustion chamber did not show any damage and oxidation relating to any specific thermal stress. Deposits of magnetic and non-magnetic material were found in the combustion chamber.

Turbine

Small pieces of debris, traces of metallisation and impact were visible on the HP and LP turbine rotor blades.

16.9.2 Engine n°2 S/N CBX 115

LP compressor module

Three blades in stage n° 1 of the LP compressor showed signs of soft body impacts. No signs of metallisation, ingestion or hard object impacts were noted. Deformations of the lower part correspond to the crushing of the casing on impact with the ground

Note : the soft body impacts were probably caused by ingestion of pieces of tyre. It is normal in such cases not to find carbonised residues in the combustion chamber, since carbon leaves no residues with temperatures above 500°C.

HP compressor module

The rotors of stage n°1, 2, and 3 of the HP compressor, on the lower part, show signs of deformation due to the impact. The n° 1 stator stage shows no signs of traces of impact. Some blades from the n° 1 stator stage are bent. From stage n°3 onwards, damage was noted on the rotors and stators, related to the clashing phenomenon. The HP compressor module showed no traces of secondary impact.

The combustion chamber

The combustion chamber showed no indications of specific thermal stress. The presence of small debris was noted during teardown operations.

Turbine

The LP and HP stages of the turbine bore no marks of foreign object damage. The overall turbine assembly had no deformations, with the exception of the part which struck the ground. The turbine showed no visible signs of rotation.

*
* *

18.1 Certification of Landing Gear and Tyres

18.1.1 General

The Concorde was certificated under specific regulations known as SST Standards. In these regulations, parts related to the landing gear are in Chapter 5-6 and those relating to the tyres are in paragraph 5-3-2. Paragraph 5-6-9 specifies requirements in case of tyre burst or damage to the landing gear.

18.1.1.1 Tyre Requirements

The tyres must comply with certain physical and chemical characteristics. In addition, the wheel-tyre-brake assembly must be subjected to static tests as well as to endurance and burst tests. In case of a burst, the tyre, inflated with water at a pressure equal to four times the nominal pressure, must not burst before reaching that pressure.

There are no indications concerning the tyre burst mode. In particular, no study is made of how it disintegrates, the size or weight of the debris.

There is no dynamic destructive test for the tyre.

Note : these requirements are not specific to the Concorde. To conform to the certification requirements, tyre manufacturers usually refer to the specifications of TSO 162-C. In the case of the Concorde, these specifications had been adapted and inserted into a document entitled the Qualification Test Program (QTP).

18.1.1.2 Landing gear Requirements

In accordance with § 5-6-9 of the SST Standards, parts and equipment placed in the area of the landing gear must be protected so as not to endanger operation of the aircraft in the following cases : tyre burst with the landing gear extended, retracted or in transit ; being struck by a strip of tyre in a situation where the wheel is able to turn ; overheating of a wheel due to excess braking.

18.1.2 Means of Compliance at the Time of Certification

At the time of certification, the aircraft was equipped with Kleber or Dunlop tyres. These tyres were in conformity with the QTP and had passed the tests relating to load, installation on the aircraft, imperviousness, as well as the static and endurance tests.

Conformity to § 5-6-9 of the SST Standards (resistance to a tyre burst) was checked by the Airworthiness authorities on 5 October 1973 on aircraft n° 1. This was the subject of report 410.198.73 in which no particular problems were noted.

For the Concorde, the tyre requirements mainly differ from the TSO in the domain of the definition of the tyres on the aircraft, with stricter tests, in particular with regard to load resistance (tyres inflated and deflated).

After the Washington accident, certification requirements imposed a reinforcement of the QTP, in order to increase the resistance of the tyres so that they could bear twice the normal load (as against 1.5 for other aircraft).

FIRST ANALYTICAL ELEMENTS : HISTORY OF THE FLIGHT

The flight has been broken down into three phases :

Phase 1 : from the beginning of the CVR recording to the application of takeoff-power

Phase 2 : from the application of takeoff power to final loss of thrust on engine 1,

Phase 3 : loss of control of the aircraft.

Phase 1

At the beginning of the CVR recording item 17 on the checklist, « cockpit check» was under way. The crew indicated the following data : fuel loaded 95 tons, V2 at 220 kt.

At 14 h 14 min 04 s, the pre-start checklist began. The crew stated the data from flight preparation, in particular the ZFW/ZFCG : 91.9 t/52.2%, the total weight of aircraft and fuel : 186.9 t and 95 t, the V1 VR V2 V2+20 noise abatement speed : 150 198 220 240 280 kt, three engine attitude : 13°. The pre-start checklist ended about two minutes later. Practically at the same time, the crew was informed that the replacement of the engine 2 thrust reverser was complete.

Between 14 h 17 min 02 s and 14 h 19 min 06 s, the FE began a test on the BLUE hydraulic system because of a low level on that circuit. The test was satisfactory.

At 14 h 20 min 06 s, the Dispatcher gave the crew the final load sheet which was accepted by the Captain. Amongst other things, he informed him of a fuel allowance of two tons for taxiing. The crew updated the takeoff weight to 185.1 tons and corrected the ZFCG to 52.3%.

At 14 h 25 min 54 s engine startup began. The four engines started up normally and the aircraft was authorised to taxi a few minutes later.

At 14 h 37 min 29 s, the taxiing check list was interrupted following the appearance of the PFC alarm : the BLUE electrical system failed and the crew decided to select the GREEN electrical system to control the rudder.

At 14 h 40 min 23 s, the FE announced 800 kg of fuel consumed during the taxiing phase, which corresponded to a takeoff weight of 186 tons. At this weight there is no limitation related to takeoff performance and the calculated parameters for V1 and VR are the same as for the MTOW (185.07 tons). The V1 callout is effectively made 33 seconds after powering up the engines, which corresponds to the time established during simulations at the MTOW.

At 14 h 40 min 37 s, pre-takeoff checklist began. The stated CG of 54.2% had been modified, by the transfer of fuel during taxiing, to the value of 54%. The temperature of the brakes was 150°.

At 14 h 42 min 17 s, the Concorde was cleared to line up and take off.

Phase 2

At 14 h 42 min 30 s, FDR reference time 91561, the characteristic click of the four thrust levers is heard. One second later the Captain announced takeoff. A change in background noise is perceptible, a noise similar to an increase in air conditioning flow and engine speed.

The FE announced the four reheats at 14 h 42 min 43 s and the four green lights fourteen seconds later. These announcements confirm the engines were in good working order, including post combustion.

The callouts for 100 knots and V1 were done at 14 h 42 min 55 s and 14 h 43 min 03 s. Acceleration to V1 was in exact conformity with the simulation calculated at MTOW.

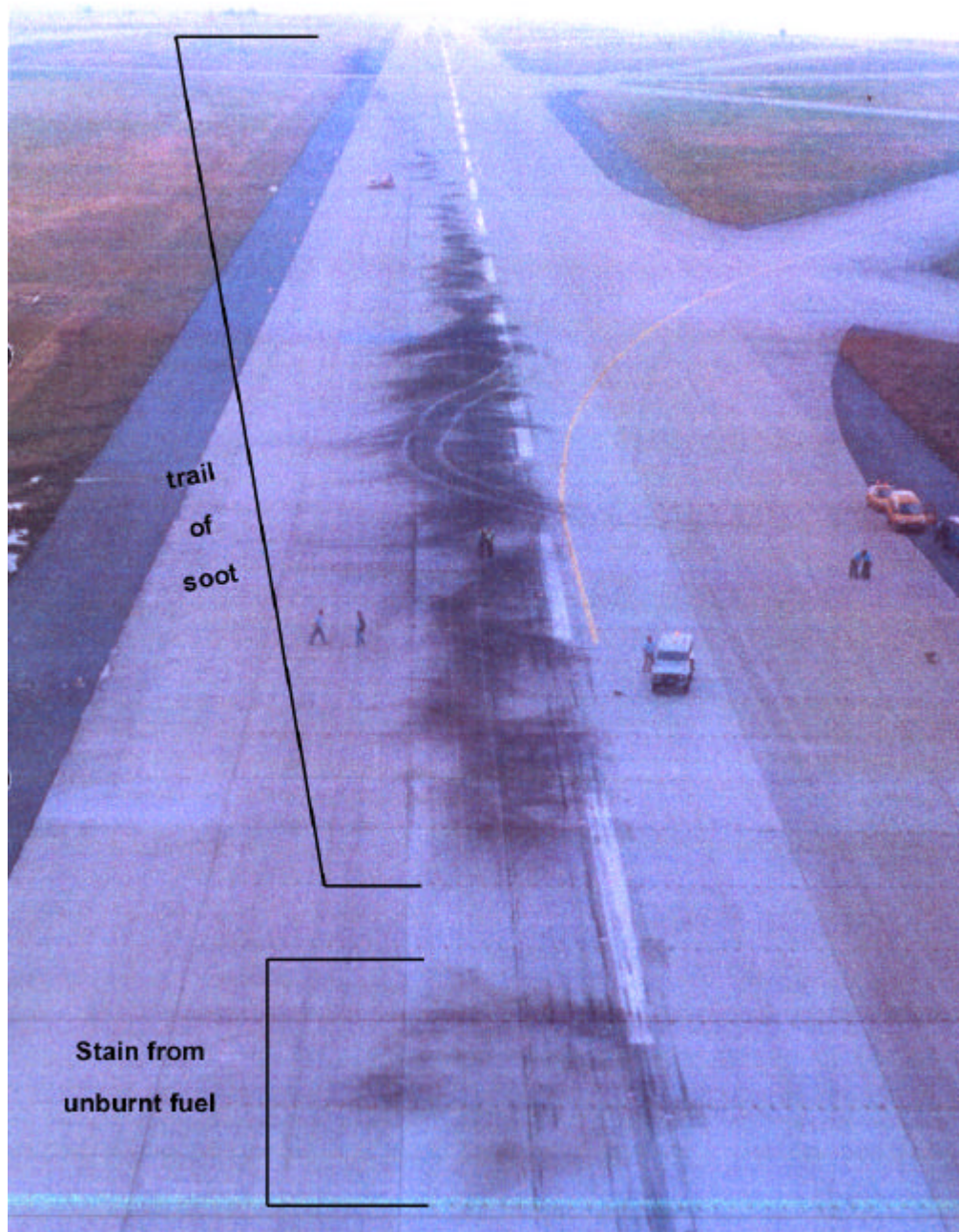

At 14 h 43 min 10 s, a clear, short noise is heard. The speed of the aircraft was 175 kt and the distance from the runway threshold was 1,722 metres. It was from that point onwards that the first parts of the water deflector, pieces of tyre and the metal strip from the DC 10 were found. A slight heading deviation to the left can then be noted at a rate estimated at 1°/s.

At 14 h 43 min 11 s, a very clear change in the background noise is heard and the first tyre marks from wheel n° 2 appeared on the runway. The speed of the aircraft was 178 kt and the distance run was 1,800 metres. The piece of tank 5 was found at this place. A large unburned kerosene stain was identified a few metres further on. Longitudinal acceleration was still nominal and constant (N_x : 0.268 g). In the following second, an incomprehensible word is heard. The speed was 182 kt and the distance run was 1,885 metres. The first traces of soot appeared on the runway. The Captain began to steer to the right and almost immediately began to pull the nose up. Engine thrust and longitudinal acceleration were still nominal.

At around 14 h 43 min 13 s, minimum longitudinal acceleration was recorded (N_x : 0.133 g) and the GO LIGHTS for engines 1 and 2 went off, confirming a loss of thrust on both engines (estimated as slight for engine 1 and high for engine 2). The FO said «watch out » (at this stage of the investigation it is not possible to explain this exclamation). A second more significant heading deviation to the left can be noted, at a rate calculate as 2°/s, probably linked to the yaw caused by the loss of thrust from engines 1 and 2. The controller told the crew that flames were visible behind the aircraft. The nose gear left the ground while a second movement of the rudder pedal is recorded, to counter the yaw movement caused by the loss of thrust from engines 1 and 2. The change in the background noise heard three seconds earlier stops. The speed was 188 kt and the distance run was 2,090 metres.

At 14 h 43 min 16 s, the heading deviation to the left was at its maximum when the rudder deflection reached 20°, then stabilised at 10° (the rudder deflection range is from -28° to +28°) . Engine 1 recovered about 90% of its nominal thrust. At the same time, the FE announced something (not understood at present). The engine 1 GO LIGHT came back on, that of engine 2 stayed off with thrust severely affected.

At 14 h 43 min 20 s, engine 1 practically recovered its nominal thrust. The FE announced « failure engine 2 ». the announcement was logical considering the drop in N_2 of over 5%, which confirms an engine failure. (the nominal N_2 at takeoff is around 103%). The speed was 203 kt, the distance run was 2,750 metres and the longitudinal pitch was +9°. Engine 2's parameters were now rising slightly.

Between times 14 h 43 min 18 s and 14 h 43 min 21 s, the GO LIGHTS for engines 1 then 3 and 4 went off, which is normal bearing in mind lift off of the left main landing gear shock absorber. At the end of this time period, a runway left edge light was torn out by wheel 6 of the left main landing gear. In the same time frame, a selector noise is heard which has been identified as movement of the TCU from MAIN to ALTERNATE. This normal action is intended to switch the computers. A few tenths of a second later, a significant deceleration of engine 1 is identified, among other things via the parameters; FF : 1.323 t., N_1 : 50%. N_2 :

74.8% recorded at 14 h 43 min 24 s. A right hand movement on the rudder pedal is also recorded.

Work being undertaken suggests that the significant loss of thrust on engines 1 and 2 was due to ingestion of kerosene and/or hot gases coming from ignition of the leak. The slight initial loss of thrust on engine 1 would have resulted from absorption of small pieces of debris associated with the destruction of the tyre.

Lift-off occurred at 14 h 43 min 22 s, speed was 205 kt the pitch was +10° and the distance run was 2,900 metres. In the same second, the engine 2 red fire warning came on. The associated gong is heard a little later.

At 14 h 43 min 23 s, engine 2's parameters are recorded with a slight fall; FF : 3.485 t/h, N1 : 57%, N2 : 77.5%.

At 14 h 43 min 24 s, the FE announced « shut down engine 2 », and the radio altimeter indicated 25 feet. At 14 h 43 min 25 s, the Captain asked for « engine fire procedure ». In the same second, a selector noise, which has not yet been identified, is heard, the FDR Engine Warning parameter switched to « de-activated » and the fire alarm stopped.

At 14 h 43 min 27 s, the FO announced « watch the airspeed, the airspeed, the airspeed ». Speed was then 200 kt for a three engine Vzrc with gear extended of 205 kt. In the following second, a selector noise is heard which was identified as being the artificial feel selectors disengaging. A gong is also heard, identified as the alarm which follows the selector disengagement. Engine 2's N2 speed fell below 58%, leading to the mode change to CONTINGENCY for engines 3 and 4. Engine 1, recovering thrust, would also change to CONTINGENCY mode seven seconds later (the thrust provided would then be equal to an engine at full thrust with reheat without CONTINGENCY). At the same time, 14 h 43 min 28.7, engine 2 was no longer being supplied with fuel and its N1 and N2 parameters are characteristic of a windmilling engine.

At 14 h 43 min 29 s, a selector noise identified as a fire handle is heard. N.B. : the engine 2 fire handle was found in the pulled position in the wreckage .

At 14 h 43 min 30 s, the Captain called for the gear to be retracted. Speed was 200 kt, the radio altimeter indicated 100 feet and the calculated climb rate was +750 ft/min. In the following seconds, the controller confirmed to the crew that there were strong flames behind the aircraft and the FE repeated « the gear ». The alarm indicating detection of smoke in the toilets is heard. (this alarm has not yet been explained).

At 14 h 43 min 35 s, the FE repeated for the FO « the gear (Jean) ». Engine 1 was running normally. In the following second, a gong is heard : this was most likely the alarm indicating low oil pressure due to the shut down of engine 2.

At 14 h 43 min 37 s, the FE repeated « the gear », the FO answered « no ». It is very likely that the red WHEEL light situated next to the gear retraction controls was illuminated by detection of under-pressure of the tyre destroyed on

wheel n° 2. In this case, the procedure requires that the landing gear should not be retracted.

At 14 h 43 min 39 s, the Captain ordered « gear retract » and three seconds later the engine 2 fire alarm was reactivated with its associated gong. It stopped a few seconds after the FE fired the extinguisher bottles. At 14 h 43 min 45 s, the FE stated « I'm firing it ». N.B. the two extinguishers situated in the left wing were found fired off in the wreckage. At the same time, the Captain asked « (are you) shutting down engine two there » and the FE answered « I've shut it down ».

At 14 h 43 min 49 s, the FO said « the airspeed ». The speed was then about 200 kt. This warning is repeated again about ten seconds later. The first differences between the plane's attitude and the pilot's actions on the flight controls begin to appear, differences which could be explained by damage to the left wing caused by the fire, in particular at the level of the left inner elevon. The angle of attack was then 13°.

At 14 h 43 min 56 s, the FO stated « the gear isn't retracting ». This non-retraction of the landing gear has not yet been explained. Two hypotheses can be proposed:

- The loss of the GREEN hydraulic system which commands the retraction of the landing gear (although no gong associated with this loss is heard),
- One of the conditions for retraction of the gear is not met (see § 6.2.2 in the preliminary report).

At 14 h 43 min 58 s, the engine 2 fire alarm sounded for the third time, and continued to sound until the end of the flight. In the following second, the GPWS « Whoop Whoop Pull Up » warning is heard three times. This is in accordance with mode 3 of the GPWS which is set off when the following three conditions are met:

- nose 5°,
- radio altimeter altitude >100 ft,
- descent rate >100 ft/min.

At 14 h 44 min, a first disturbance of engine 1's FF and P7 parameters is noted. A second disturbance is recorded eight seconds later. At the same time, the rudder switched to mechanical mode, which led to the loss of the yaw auto-stabilisation function. Roll/pitch and fore-and-aft control/tilt interactions are noted, which might confirm the loss of effectiveness of the left inner elevon.

At 14 h 44 min 12 s, engine 1's parameters show a clear deceleration. This seems to result from the ingestion of kerosene and hot gases produced by the fire and internal damage caused by ingestions at takeoff. Only engines 3 and 4 were still running.

Phase 3

In the following twenty seconds, the angle of attack would vary over twelve seconds from 12° to a value above 25° , left roll would pass from 2.13° to 113° (a value recorded 4 seconds before the end of the recording) and the heading would vary from 270° to 115° . The significant loss of thrust from engines 3 and 4 is recorded five seconds before the end of the recording, probably due to distortion of the air entering the intakes, the angle of attack being above 25° and the left roll close to 100° .

In these extreme conditions, no detailed examination was carried out on the loss of control leading to the impact, which was probably due to the combination of lateral asymmetry, significant thrust/drag imbalance and structural damage caused by the fire. In fact, since the aircraft had exceeded the angle of attack and roll values approached during the certification tests, there is no data available which would allow its behaviour in such conditions to be described.

APPENDIX PREVIOUS EVENTS

Year	Date	Registr.	Place	Circumstances	Event	Cause	Phase	Damage
1976	15/12/76	F-BVFB	Paris	Burst tyre 2	Burst		Taxi	No other damage
1977	22/07/77	F-BVFA	Washington	Burst tyres 1 and 2	Burst	FOD	Taxi	Deflector
1977	19/12/77			Deflation tyre 4	Deflation		Landing	Slight loss of tread
1978	02/08/78	G-BOAD		Burst tyre 2	Burst		Landing	Hydraulic leak Deflector
1978	10/12/78	F-BVFA		Burst tyre 7	Burst		Taxi	
1978	12/12/78	F-BVFA		Burst tyre 1	Burst		Taxi	
1979	04/02/79	F-BVFC	Washington	Burst tyre 2	Burst		Taxi	
1979	15/03/79	F-BVFC	Dakar	Burst tyres 5 and 6	Burst	FOD	Takeoff	Engines 1 & 2 replaced Wheel and brake damage gear locking hydraulics
1979	02/06/79	F-BVFC	New York	Loss of tread tyre 6	Loss of tread		Takeoff	Impact on wing Hydraulic servovalve fairing Damage to gear
1979	14/06/79	F-BVFC	Washington	Loss of tread tyre 6 Burst tyre 5	Loss of tread and burst	Deflation	Takeoff	Destruction of wheel, damage to left gear, hydraulic and electrical circuits, wing skin Tanks 2, 5 and 6 penetrated Engine 2
1979	21/07/79	F-BVFD	Washington	Burst tyre 6	Burst		Takeoff	Engine 2 Engine 2 air intake Traces of rubber observed on the wing just above the burst tyre
1979	23/09/79	F-BVFB	Dakar	Loss of tread tyre 3	Loss of tread		Takeoff	Engine 3 replaced Left gear damaged
1979	06/10/79	G-BOAA	London	Burst tyre 4	Burst	FOD	Takeoff	Wheels n° 7 and 8 Engines 3/4
1979	31/10/79	F-BVFD		Loss of tread tyre 7	Loss of tread	FOD	Takeoff	
1979	21/12/79	G-BOAB	London	Burst tyres 5, 6, 7, 8	Burst	Electrical failure	Landing	Engine 3 deflector
1980	05/02/80	G-BOAD	London	Burst tyre 8	Burst	Braking system jam	Landing	Green/yellow hydraulics Brakes Deflector
1980	16/07/80	F-BVFC		Burst tyre 3	Burst		Taxi	
1980	16/09/80	G-BOAF	London	Burst tyre 8	Burst		Takeoff	Engine 3 Gear door Deflector
1981	19/02/81	F-BTSD	Washington	Burst tyre 2	Burst	FOD	Takeoff	Engine 1 & 2 replaced
1981	13/07/81	F-BVFF	Paris	Loss of tread tyre 5	Loss of tread	FOD	Takeoff	Engine 2 and gear

Year	Date	Registr.	Place	Circumstances	Event	Cause	Phase	Damage
1981	09/08/81	G-BOAG	New York	Burst tyres 1 and 2	Burst		Takeoff	Impacts on wing Tank 5 penetrated Hydraulics Elevon Engines 1/2/3
1981	20/09/81	G-BOAD	New York	Burst tyre 6	Burst		Takeoff	Impacts on fuselage Engine 2 Brake servovalve damaged Deflector
1981	14/12/81	G-BOAC	London	Burst tyres 1 and 2	Burst		Takeoff	Yellow hydraulics Engines 1/2 Deflector
1981	26/12/81	G-BOAE	New York	Deflation tyre 2	Deflation		Taxi	No other damage
1982	30/04/82	G-BOAF	London	Deflation tyre 4	Deflation		Taxi	No other damage
1982	03/06/82	F-BVFB	Paris	Burst tyre 6	Burst		Landing	Hydraulics and gear
1982	04/08/82	F-BVFB		Burst tyre 4	Burst		Taxi	
1982	19/09/82	F-BTSC		Burst tyre 4	Burst		Taxi	
1983	09/05/83	F-BVFB	New York	Burst tyre 1 or 2?	Burst	FOD	Taxi	2 wheels replaced
1984	08/03/84	G-BOAC	New York	Burst tyre 2	Burst		Takeoff	Impacts on wing Engine 2 Deflector
1984	29/04/84	G-BOAE	London	Deflation tyre 8	Deflation	Wear to braking system	Landing	No other damage
1984	11/07/84	G-BOAD	London	Burst tyre 1	Burst		Landing	Brakes Deflector
1984	14/08/84	G-BOAA	London	Burst tyre 4	Burst		Taxi	Deflector
1985	20/02/85	F-BVFF	New York	Burst tyre 8	Burst	Servovalve	Landing	Wheel and gear hydraulics
1985	27/02/85	G-BOAE	New York	Loss of tread tyre 4 and 8	Loss of tread		Taxi	
1985	14/11/85	G-BOAE	London	Burst tyre 7	Burst		Landing	Hydraulic fire
1985	15/11/85	G-BOAB	London	Burst tyre 5	Burst	FOD	Takeoff	Impacts on fuselage, damage to brake door Tank 5 penetrated Engines 1 and 2 Deflector+I67
1986	18/05/86	F-BVFB	Paris	Burst tyre 5	Burst	FOD	Taxi	No other damage
1987	11/08/87	G-BOAC	New York	Burst tyres 1,2,4,5,6 and 8	Burst	Braking system	Landing	Impacts on wing Engine 3 Gear doors Deflector Brake fan
1987	10/09/87	F-BTSD	New York	Deflation tyre 8	Deflation	FOD	Takeoff	No other damage
1988	29/01/88	G-BOAF	London	Deflation tyre 3	Deflation		Takeoff	Loss of wheel bolts. Impacts on wing Tank 7 damaged

Year	Date	Registr.	Place	Circumstances	Event	Cause	Phase	Damage
1988	09/03/88	G-BOAC	London	Burst tyre 1	Burst	Braking system	Landing	Hydraulics
1988	10/04/88	F-BTSD	New York	Loss of tread tyre 7	Loss of tread	FOD	Takeoff	Brake hydraulics
1990	14/08/90	F-BVFA	Paris	Burst tyre 5	Burst	FOD	Taxi	No other damage
1992	13/02/92	G-BOAG	London	Loss of tread tyre 7	Loss of tread		Takeoff	Deflector
1992	27/03/92	F-BTSC	New York	Burst tyre 1	Burst	FOD	Takeoff	No other damage
1992	04/09/92	F-BVFF	New York	Deflation tyre 4	Deflation	FOD	Taxi	Wheel
1993	16/01/93	F-BVFF	Paris	Loss of tread tyre 7 and 8	Loss of tread	FOD	Takeoff	SV fairing, right MLG, right gear strut, actuator, Tyre mark air intake 3 Engine 3 Deflector wheel 8 Wing root fairing
1993	15/07/93	G-BOAF	London	Burst tyre 4	Burst	Braking system jam	Landing	Impacts on wing Tank 8 penetrated Green hydraulics Engine 3 Deflector
1993	28/07/93	F-BVFC	New York	Loss of tread tyre 2	Loss of tread	Servo valve	Landing	Brake 2 piping
1993	25/10/93	G-BOAB	London	Burst tyre 2	Burst	Braking system jam	Taxi	Impacts on wing Deflector Tank 1 penetrated
1995	21/07/95	G-BOAB	London	Burst tyre 2	Burst		Taxi	Hydraulic leak
1998	22/07/98	F-BVFF	Paris	Burst tyre 8	Burst	Servo valve	Taxi	No other damage
1998	28/08/98	G-BOAE	New York	Deflation tyre 3	Deflation	FOD	Taxi	No other damage
2000	22/01/00	F-BVFF	New York	Burst tyre 4	Burst	Servo valve	Landing	No other damage
2000	13/06/00	G-BOAF	London	Burst tyre 6	Burst		Landing	No other damage
2000	14/07/00	G-BOAB	London	Burst tyre 1	Burst	FOD	Takeoff	Deflector